



# PEV-200 DRUM FILTER

## Product Specification Sheet

### DESCRIPTION

- Pure Effect's PEL-190 Drum Filter is a 55 gallon drum designed for vapor phase treatment applications up to 100 CFM. The steel drum series contain all the operating elements found in a full-scale adsorption system.
- The PEV-200 model is designed to hold up to 200 lbs. of media and is a versatile vessel for soil vapor extraction, pilot testing, vent tests, tank venting, odor control and emergency response.

### FEATURES

- Quality UN rated steel drums
- Enamel exterior finish
- Flow rate recommended: 100 cfm
- Simple setup and operation
- Inlet distributor capabilities
- Easy to ship and handle for low cost field work
- Reactivation and disposal of GAC available
- Wide range of contact media available

### TECHNICAL

- Max fill: 200 lbs. granular activated carbon (GAC)
- Pressure drop: 100 cfm: 6-7" wc
- Max pressure: 6 psi
- Design flow rate: 100 cfm
- Max operating temp: 130° F
- Overall dimensions: 24" dia. x 36" overall ht.
- Inlet and outlet size: 2" NPT threaded
- Shipping weight with carbon fill: 240 lbs.

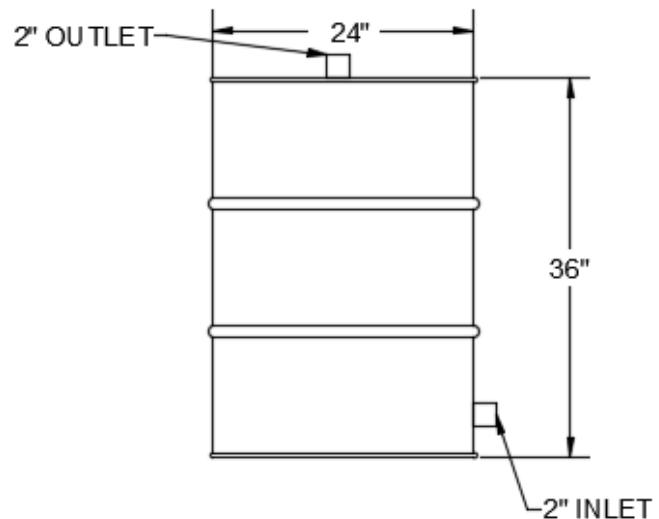

**Adhere to all applicable health & safety regulations when using this product.**