



PEL-190 DRUM FILTER

Product Specification Sheet

DESCRIPTION

- Pure Effect's PEL-190 Drum Filter is a 55 gallon drum designed for liquid phase treatment applications up to 10 gpm. The steel drum series contain all the operating elements found in a full-scale adsorption system.
- The PEL-190 model is designed to hold up to 190 lbs. of carbon and is a versatile vessel for low flow treatment needs.

FEATURES

- Quality UN rated steel drums
- Plastic liner
- Baked exterior coating
- Flow rate recommended: 5 gpm (10 gpm max)
- Simple setup and operation
- Inlet distributor capabilities
- Easy to ship and handle for low cost field work
- Reactivation and disposal available
- Wide range of contact media available

TECHNICAL

- Max fill: 190 lbs. granular activated carbon (GAC)
- Recommended pressure: 5 psi, max pressure: 7 psi
- Design flow rate: 5 gpm (10 gpm max)
- Max operating temp: 130° F
- Overall dimensions: 24" dia. x 36" overall ht.
- Inlet and outlet size: 2" NPT threaded
- Shipping weight with carbon fill: 240 lbs.

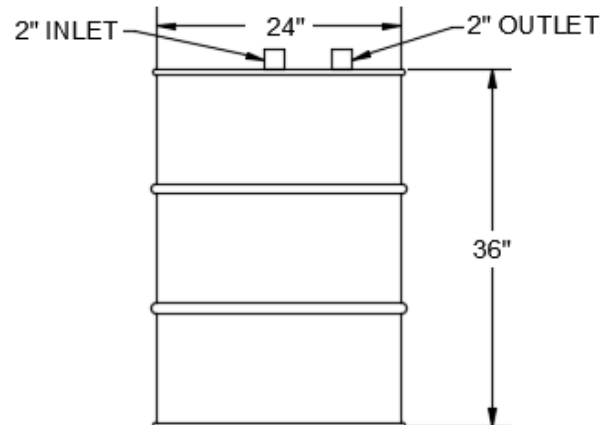

Adhere to all applicable health & safety regulations when using this product.